

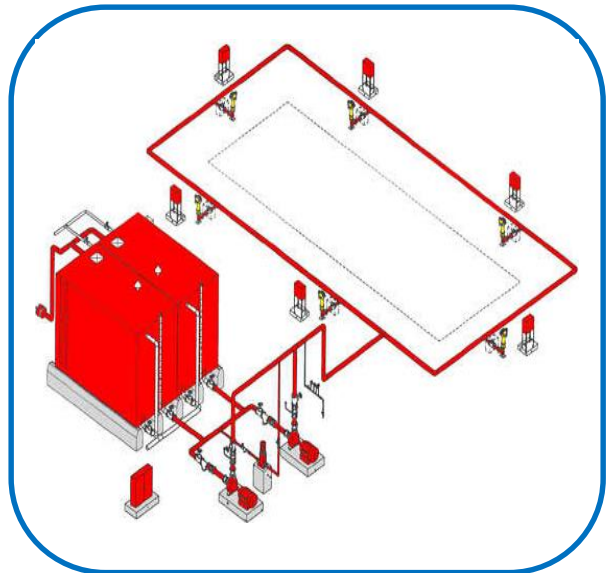

Fire Detection & Alarm System

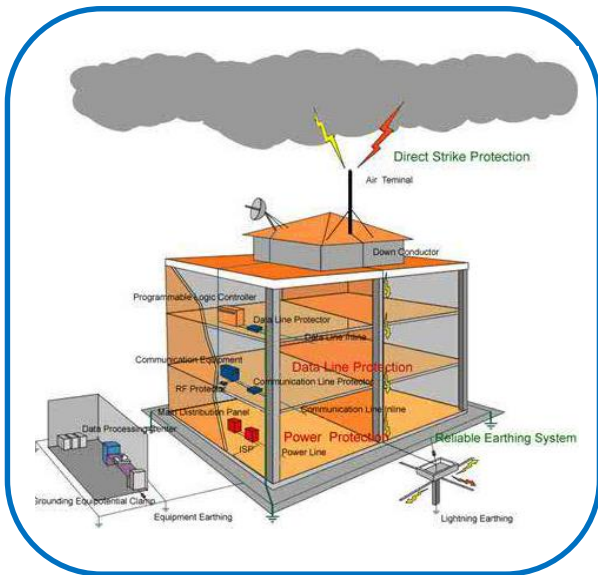

Fire Hydrant & Sprinkler System



Lightning Protection System

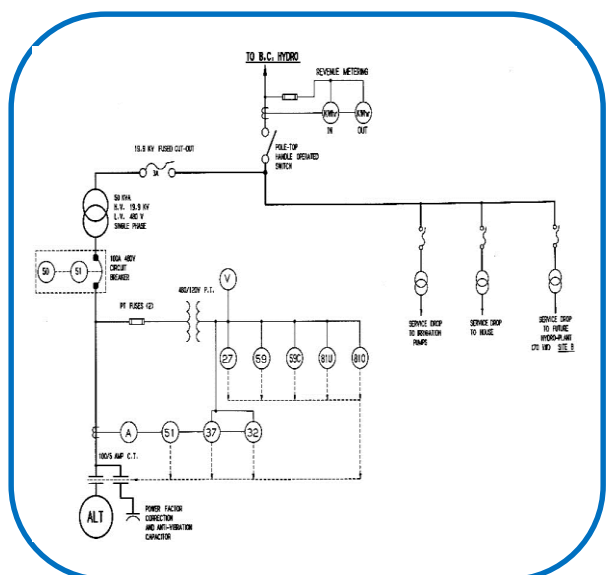

Electrical Single Line Diagram

We are Provider of Fire Safety and Electrical Consultancy as per NFPA, BNBC, Accord and Alliance Standard.

Electrical Single Line Diagram

ELECTRICAL DESIGN AND DRAWING

● ELECTRICAL SINGLE LINE DIAGRAM

OWNER / CLIENT
SMUG SWEATER LIMITED
TELEPARA, CHANDONA,GAZIPUR,BANGLADESH

ACCORD ID: 9521

CONSULTANT

ELECTROMECH ENGINEERING

Office:56(2nd Floor), Shafiq Monjil,Abdullapur(Paper Mill Road),Uttara,Dhaka-1230

Team A

Acknowledges with suggestions.
We'll check it and follow up.

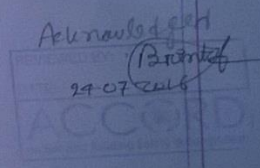
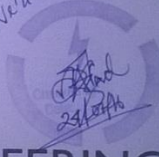

Lightning Protection System

LIGHTNING PROTECTION SYSTEM

OWNER / CLIENT
BESTEC BD LIMITED
PLOT NO : 43,44; SECTOR: 02;
KARNAPHULI EXPORT PROCESSING ZONE
NORTH PATENGA, CHITTAGONG

(ACCORD ID: 11841)

DESIGNER
ELECTROMECH ENGINEERING
56, Shofiq Monjil, Abdullapur, Uttara, Dhaka-1230, Bangladesh

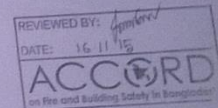

Fire Detection and Alarm System

All Products to be used in the system shall be certified by
Paper and Poly Carbonate tube for details about and price can
contact please follow Accord website.

ADDRESSABLE FIRE ALARM AND DETECTION SYSTEM

BESTEC BD LIMITED
PLOT NO : 43,44; SECTOR: 02;
KARNAPHULI EXPORT PROCESSING ZONE,
NORTH PATENGA, CHITTAGONG.

ACCORD Id No: 11841

CONSULTANT
ELECTRO-MECH ENGINEERING
56, Shofiq Monjil, Abdullapur (Paper Mill Road)
Uttara, Dhaka-1230

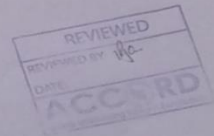

Stand Pipe and Hose System

DRAWING NAME: FIRE FIGHTING SYSTEM

OWNER / CLIENT NAME:

BESTEC BD LIMITED., (ACCORD ID: 11841)
Plot no : 43,44; Sector: 02;
Karnaphuli Export Processing Zone,
North Patenga, Chittagong.

CONSULTANT NAME:

ELECTROMECH ENGINEERING
56, Shofiq Monjil, Abdullapur (Paper Mill Road)
Uttara, Dhaka-1230, Bangladesh

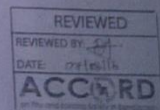

Fire Door Installation Certificate

CERTIFICATE of INSTALLATION SERVICE

Country of **BANGLADESH**

THIS IS TO CERTIFIED THAT

ELECTRO-MECH ENGINEERING

Address: 56, Shofiq Monjil, Abdullapur, Uttara, Dhaka-1230, Bangladesh

Contact No: +88 01712 916 938, 01707 000 070

E-mail: info@emechbd.com, firesafety@emechbd.com

Web Site: www.emechbd.com

Has BEEN APPOINTED AS INSTALLATION SERVICE FOR BANGLADESH MARKET OF UL LISTED FIRE DOOR FROM THE UNDERSIGNED COMPANY



Period of validity: From 2015-10-25
To 2016-10-24

CHANGCHUN ZHUCHENG, CHINA



Changchun Zhucheng
Group Co., Ltd.

[Email: export@zhuchenggroup.com](mailto:export@zhuchenggroup.com) \ [Website: www.zhuchenggroup.com](http://www.zhuchenggroup.com)



Safety Consultancy

Fire Detection and Auto Alarm System:

Design and Drawing with Voltage Drop Calculation, Battery Calculation, Conduit fill Calculation, Input Output Matrix as per NFPA-72, BNBC Guideline as well as Accord and Alliance Requirements.

Fire Protection System: Standpipe and Automatic Sprinkler System.

Design and Drawing with Hydraulic Calculation by Soft Ware as per NFPA-13,14,20, BNBC Guideline as well as Accord and Alliance Requirements.

Lightning Protection System (LPS):

Design and Drawing with Calculation as per NFPA-780, BNBC Guideline as well as Accord and Alliance Requirements.

Electrical Single Line Diagram (SLD):

Design and Drawing with Calculation as per NFPA -70, BNBC Guideline as well as Accord and Alliance Requirements.

Evacuation Plan:

Design and Drawing with Ails Mark as per NFPA and BNBC Guideline as well as Accord and Alliance Requirements.





Office and Show Room:

Jilani Market, 2nd Floor (Opposite of Jalal Shopping Center)
Dhaka – Mymensingh Road, Board Bazar, National University, Gazipur- 1704
Tel: +88 02-929 1798, Cell: +88 01708 520 643, 01708 520 644, 01707 000 070
E-mail: info@emechbd.com, sales@emechbd.com

Web Site: www.emechbd.com